

6" Solids Handling ENVIOPRIME® Pump 6JSCE-DJDST-4045D-M

With its heavy-duty cast-iron construction, ability to dry-prime and re-prime automatically, this end-suction centrifugal pump leads the industry in construction, industrial and mining applications. The Thompson 6JSCE-DJDST-4045D-M ENVIOPRIME® Solids Handling Pump is designed for high flows and moderate heads to 167 feet making it perfect for sewage bypass pumping or general construction dewatering. The 6JSCE-DJDST-4045D-M pump provides flow rates to 2,450 gpm and solids handling to 3".

Features

- Standard engine – John Deere 4045D. Available with a variety of diesel engines.
- Fully automatic, dry priming to 28 feet.
- Moderate heads to 167 feet. Maximum flows to 2,450 gpm.
- Automatic Start/Stop Control System available
- Compact unit available with detachable trailer. Also available with highway or removable drop-on Silent Knight® sound enclosure
- Maximum operating time is 39 hours @ 1,800 rpm
- ENVIOPRIME® compressor-assisted priming system prevents blow-by allowing pump to be

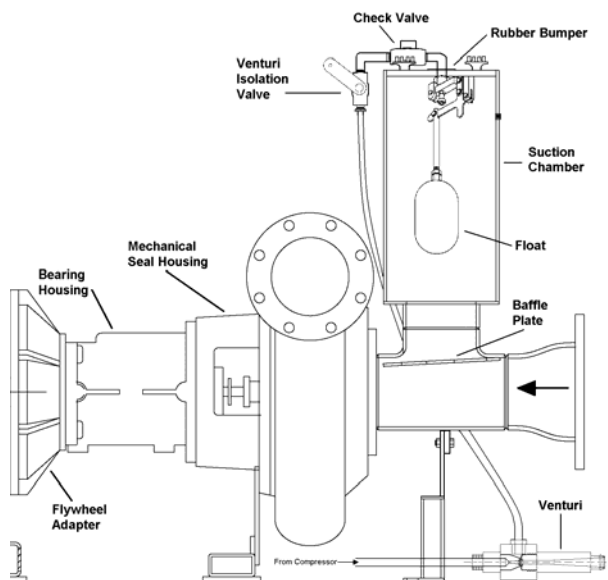

ENVIOPRIME® system

Thompson's exclusive ENVIOPRIME® dry-priming system works in conjunction with the compressor/venturi priming system to prevent blow-by, such as sewage and waste, from discharging onto the ground. The system works automatically, evacuating the air from the suction line during startup, as well as any air or gases introduced into the suction line during the pumping process.

Features and Benefits

- Handles large volumes of air, producing quicker priming times.
- Eliminates need for a venturi waste hose
- Extends the life of the pump by separating air and water, keeping the venturi from clogging and shutting down the system.
- Allows for optional noise suppressor
- This innovative system, along with high efficiency impellers, lessens power requirements resulting in reduced operating costs.

**THOMPSON
PUMP**
EXPERIENCE INNOVATION

6" Solids Handling ENVIROPRIME® Pump 6JSCE-DJDST-4045D-M

6JSCE-DJDST-4045D-M Dimensions

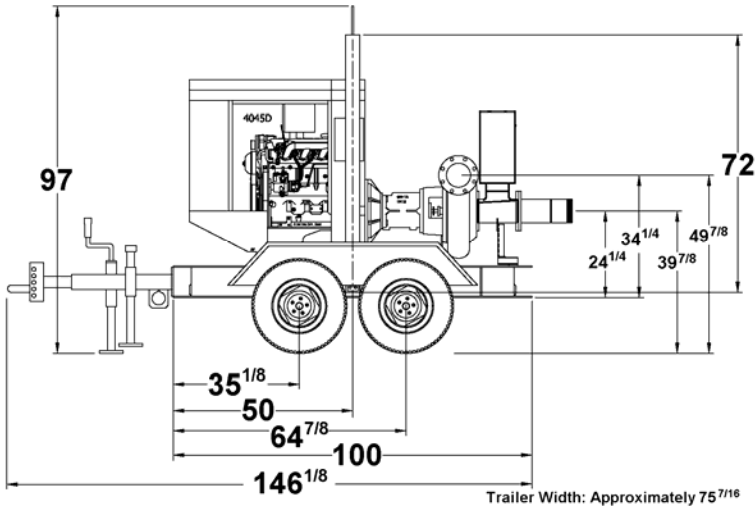

Materials of Construction

Pump Casing: Heavy-duty class 30 cast-iron
Impeller: Dynamically balanced, non-clogging, enclosed, class 30 cast iron with rear-equalizing vanes to reduce axial loading and prolong seal and bearing life; Diameter 12"
Mechanical Seal: 2.5" dry-running, oil lubricated with Tungsten Carbide rotating and Silicon Carbide stationary seal faces. Other components are 304 stainless steel and nitrile.
Head: Rugged, back pull out design, heavy-duty class 30 cast iron with tapered bore design.
Bearings: Heavy-duty grease lubricated to carry both axial and radial loads.
Frame and Suction Wear Ring: Heavy-duty class 30 cast iron
Shaft: 'Stress-proof' steel and fitted with a renewable 416 stainless steel shaft sleeve

6JSCE-DJDST-4045D-M Performance Curve

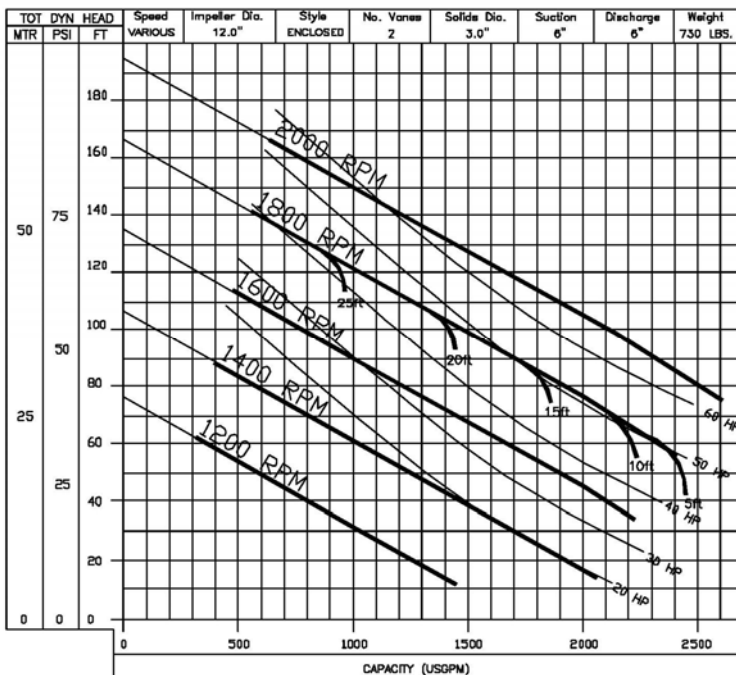

Engine Specifications

Engine: John Deere 4045D, 62 hp @ 1,800 rpm
Type: 4-cylinder, in-line, 4-cycle, water-cooled, naturally aspirated, direct-injected, Tier II diesel
Standard Equipment: Alternator, radiator, muffler, and residential grade silencer muffler
Displacement: 276 cubic inches
Fuel Economy: .379 lb/hp-hr @ 1,800 rpm
Automatic Shutdowns: Low lube oil pressure; high water temperature

Unit Specifications

Fuel Tank Capacity: 114 US gallons
Fuel Consumption: 2.9 gallons per hour
Maximum Operating Speed: 1,800 rpm
Maximum Operating Temperature: 212°F
Maximum Working Pressure: 110 psi
Maximum Suction Lift: 28 feet
Maximum Casing Pressure: 175 psi

In the interest of product improvement, Thompson Pump & Manufacturing reserves the right to change specifications without incurring any obligation for equipment previously or subsequently sold. Capacity, Head and Pump Curve are for comparative purposes. Consult engineering data for exact capabilities.
 4620 City Center Drive, Port Orange, FL, 32129, USA (800) 767-7310 * Fax (386) 761-0362
 Email: sales@thompsonpump.com * www.thompsonpump.com

