



BUILT FOR WORK



CONTRACTOR PUMPS & GENERATORS

**SAND/SOLIDS TRASH PUMP
HS/HSZ/HSD SERIES**

Electric Submersible Pumps • Engine Powered Pumps • Generators • Accessories

HS TRASH PUMP

Durable trash pumps in two sizes—a 1HP 3-inch discharge and a 1/2HP 3-inch discharge. Both designed to pump sand, solids and debris with minimal wear and clogging.

HS Features

- Built-in shaft mounted agitator suspends solids.
- Urethane Semi Vortex Impeller for maximum durability and pump performance.
- Double Inside Mechanical Seal With SiC faces provides longest operational life.
- Oil Lifter provides lubrication of the seal faces. (Patent Pending)
- V-Ring Seal design protects mechanical seal from abrasive particles.

Optional Accessories

- Vertical Discharge Coupling.
- 2-inch NPT coupling available for HS3.75S-61.



HS2.4S-62

HS3.75S-61

Model	Discharge Bore (inch)	Ship Weight (lb.)	Cable Length (ft.)	Motor Output (hp)	Dimensions (inch)		Continuous Running Water Level (inch)
					Diameter	Height	
HS2.4S-62	2	30	20	1/2	10	13	3 1/2
HS3.75S-61	3	47	32	1	12 1/2	15 1/4	3 1/2

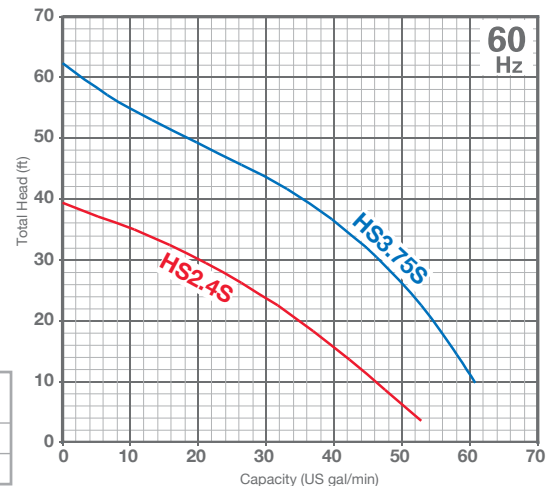

HSZ AUTOMATIC TRASH PUMP

Automatic trash pumps in two sizes, designed to pump sand, solids and debris with minimal wear and clogging.

HSZ Features

- Built-in shaft mounted agitator suspends solids.
- Urethane Semi Vortex Impeller for maximum durability and pump performance.
- Double Inside Mechanical Seal With SiC faces provides the longest operational life.
- Oil Lifter provides lubrication of the seal faces. (Patent Pending)
- V-Ring Seal design protects mechanical seal from abrasive particles.

Optional Accessories

- Vertical Discharge Coupling.
- 2-inch NPT coupling available for HSZ3.75S-61.



HSZ2.4S-62

HSZ3.75S-61

Model	Discharge Bore (inch)	Ship Weight (lb.)	Cable Length (ft.)	Motor Output (hp)	Dimensions (inch)		Continuous Running Water Level (inch)
					Diameter	Height	
HSZ2.4S-62	2	30	20	1/2	10	13	3 1/2
HSZ3.75S-61	3	47	32	1	12 1/2	15 1/4	3 1/2

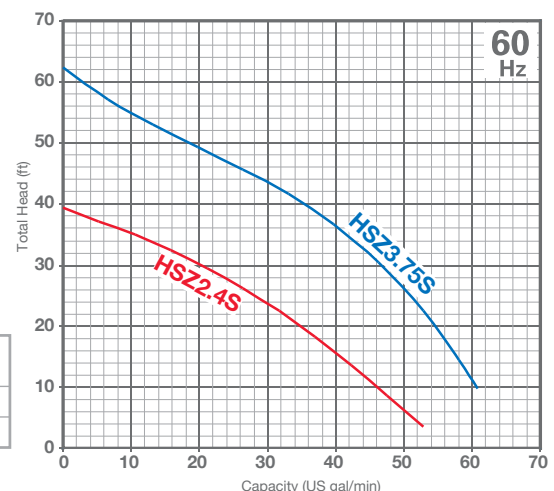

HSD SERIES SAND PUMP

Pump sand, solids and debris with minimal wear and clogging.

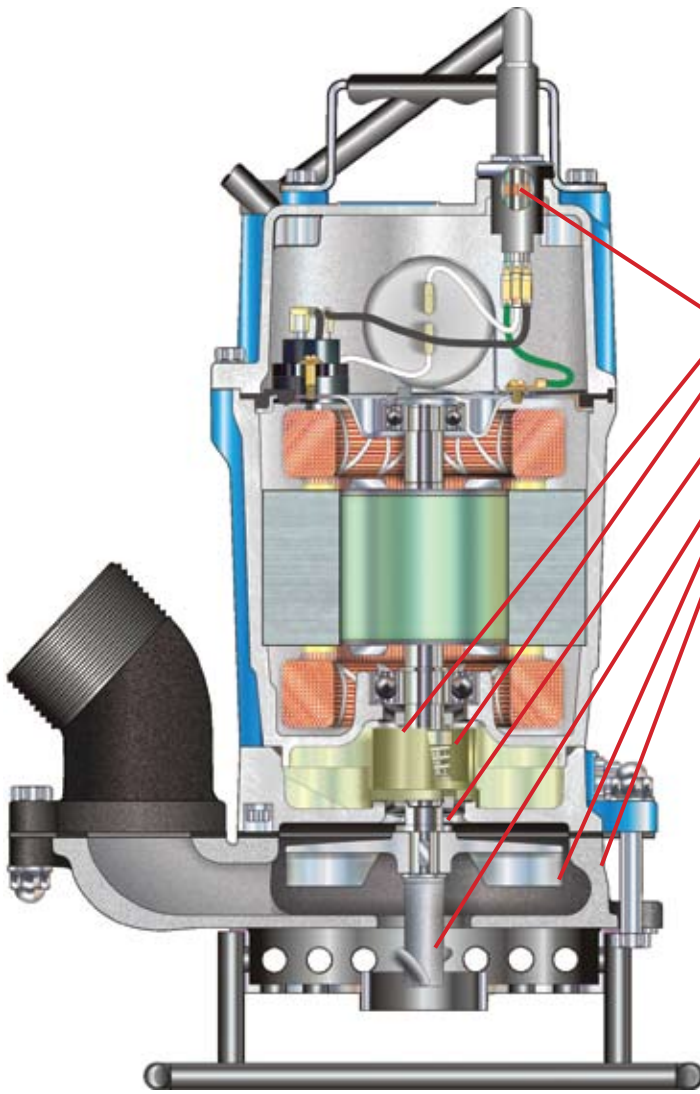

HSD Series Features

- Complete special 2 years warranty.
- Anti-wicking block prevents water incursion.
- Oil Lifter extends seal life by ten times.
- Double Inside Mechanical Seal with silicon carbide faces provides the longest operational life of any seal available.
- V-Ring Seal design protects mechanical seal from abrasive particles.
- Built-in larger shaft mounted agitator suspends solids.
- High Chromium Iron impeller.
- Ductile Iron Casing.
- 3/4 HP motor; larger than HS2.4S-62.
- Easy pump end disassembly by removing only 3 nuts.

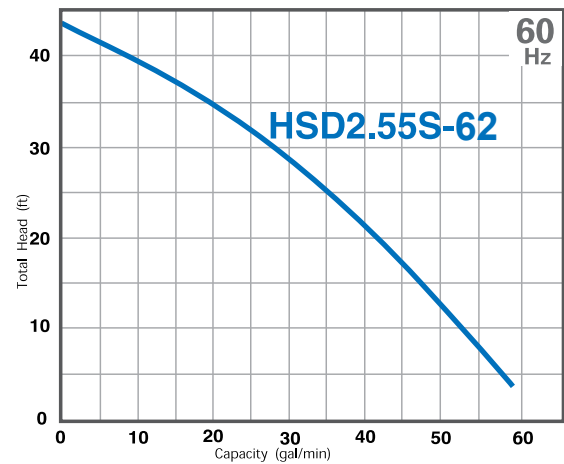

Model	Discharge Bore (inch)	Ship Weight (lb.)	Cable Length (ft.)	Dimensions (inch)		Continuous Running Water Level (inch)
				Diameter	Height	
HSD2.55S-62	2	36	16	6 3/8	15 3/8	4 1/8

The Pump Technology That The World Trusts.



Tsurumi introduced its international strategy in the 1960s. Our technical capabilities gained recognition first in Asia in the 1970s and then in the United States and Europe in the 1980s. Following the initial steps, our international division successfully penetrated many worldwide markets including: construction, civil engineering, mining, industrial, wastewater, sewage treatment, and flood control.

Today Tsurumi has expanded its base of operations and is active in 45 countries and regions. In addition to supporting a variety of work sites, our high-performance pump products are widely used in large-scale national projects where they surpass expectations. Reliable performance is our first priority.



For Sales, Service, and Specifications, call:
1-888-TSURUMI (878-7864)
1-800-748-4458 (Utah Office)



TSURUMI (AMERICA), INC.
1625 Fullerton Court
Glendale Heights, IL 60139
Tel: 1-888-878-7864 (Toll-Free)
1-630-793-0127
Fax: 1-630-793-0146



TSURUMI (AMERICA), INC. WEST
6216 West 9790 South
West Jordan, UT 84081
Tel: 1-800-748-4458 (Toll-Free)
1-801-563-5910
Fax: 1-801-563-5911

Your Dealer

OCT10-RENTAL-WEB/DIS

Visit our new website: www.tsurumipump.com